

都市型側溝 アンクルタイプ H50/70

可変勾配対応	輪荷重 縦断 T-25	CAD data	DWG SFC
--------	----------------	-------------	------------

参考布設標準構造図(路肩部)

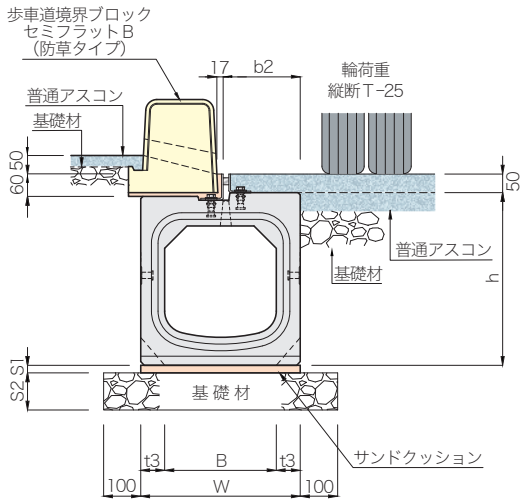

参考布設標準構造図(中央分離帯部)

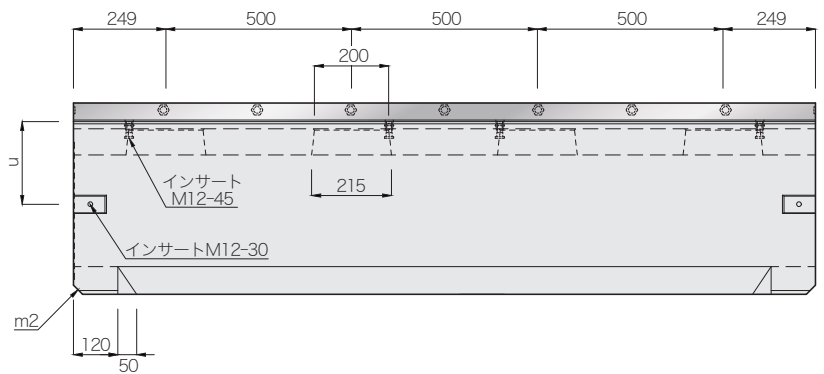
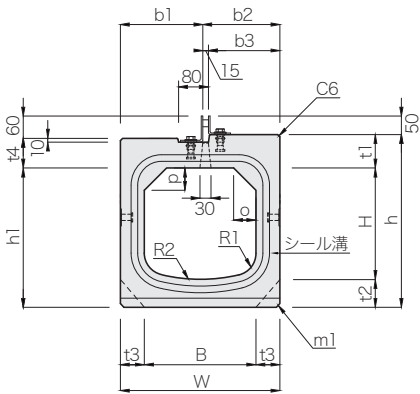
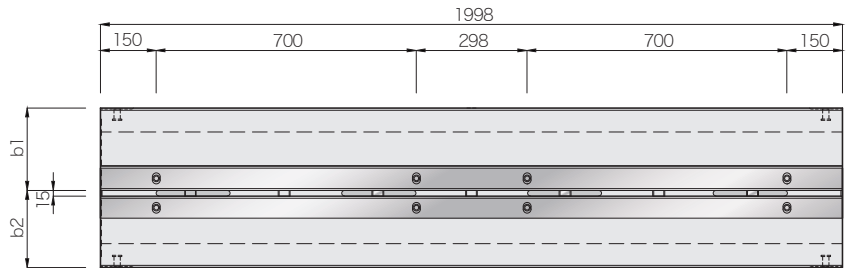
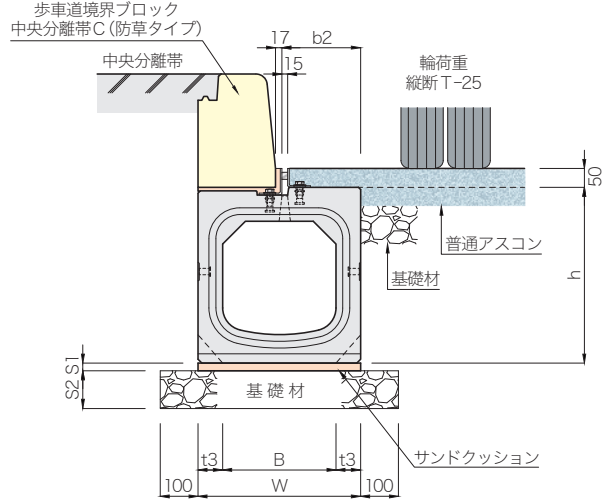

呼び名 (B×H)	寸法 (mm)																				参考 質量 (kg)	
	B	H	h	h1	W	b1	b2	b3	t1	t2	t3	t4	o	p	m1	m2	u	R1	R2	S1		S2
300× 300	300	300	465	375	430	222	208	193	90	75	65	80	60	60	10	25	223	60	450	20	100	510
× 400		400	565	475																		571
× 500		500	665	575																		632
× 600		600	765	675																	150	694
× 700		700	865	775																		755
× 800		800	965	875																		816
× 900		900	1065	975																		877
×1000		1000	1165	1075																	200	938
400× 400	400	400	590	490	540	287	253	238	100	90	70	90	80	80	20	35	287	80	600	20	100	751
× 500		500	690	590																		816
× 600		600	790	690																	150	882
× 700		700	890	790																		948
× 800		800	990	890																		1014
☆ × 900		900	1090	990																		1079
☆ ×1000		1000	1190	1090																	200	1145

注(1) ☆印につきましては型枠を整備中ですので、あらかじめ担当営業にお問い合わせください。

(2) 参考質量はアンクル(H50/70)の質量を含んでおりません。

都市型側溝 集水柵 アングルタイプ H50/70

輸荷重 縦断 **T-25** CAD data DWG SFC

グレーチング幅目対応

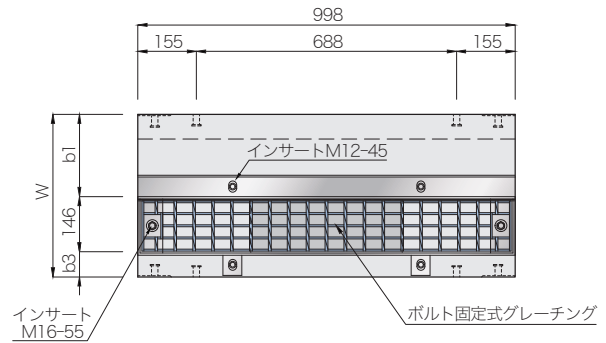

布設標準構造図(参考)

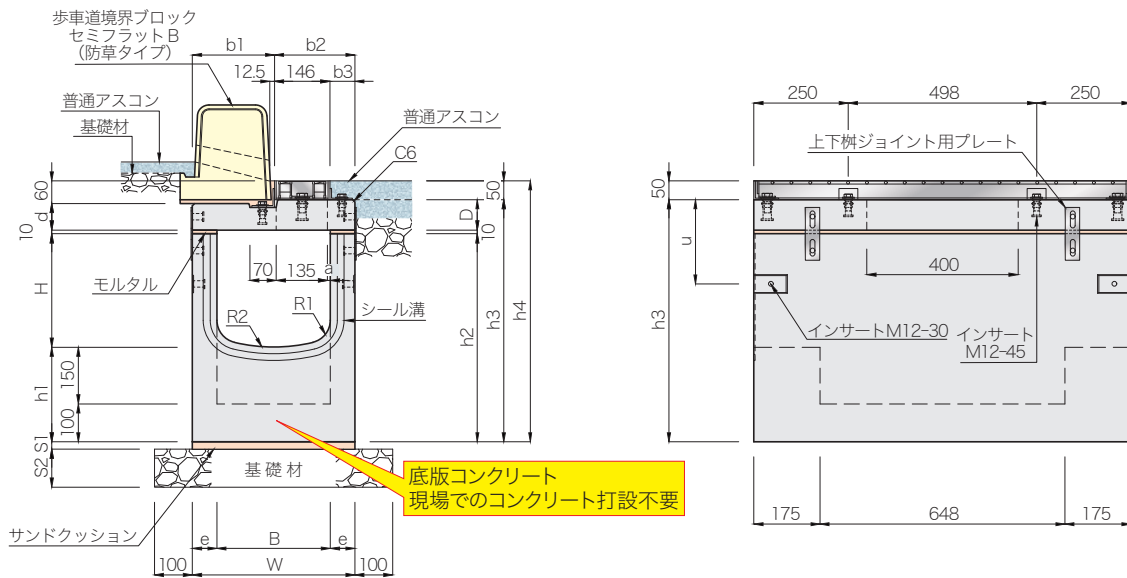

呼び名 (B×H)	寸法 (mm)																			参考質量(kg)		
	B	H	h1	h2	h3	h4	W	b1	b2	b3	D	d	e	u	a	R1	R2	S1	S2	上部柵	下部柵	合計
300× 300	300	300	250	550	640	690	430	217.5	212.5	66.5	80	70	65	223	8	60	450	20	100	80	277	357
× 400		400		650	740	790															308	388
× 500		500		750	840	890															338	418
× 600		600		850	940	990													150		369	449
× 700		700		950	1040	1090															400	480
400× 400	400	400	250	650	750	800	540	282.5	257.5	111.5	90	80	70	287	48	80	600	20	100	111	362	473
× 500		500		750	850	900															395	506
× 600		600		850	950	1000															428	539
× 700		700		950	1050	1100															461	572
× 800		800		1050	1150	1200															494	605

(注)グレーチングはボルト固定式です。また、細目仕様にも変更できます。

都市型側溝 深型集水柵 アングルタイプ H50/70

輸荷重 縦断 T-25 CAD data DWG SFC

グレーチング細目対応

300型

布設標準構造図(参考)

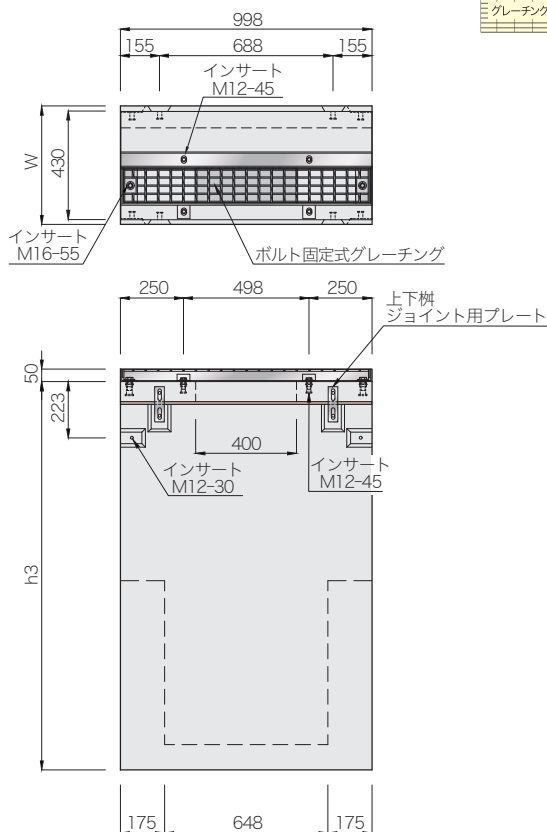
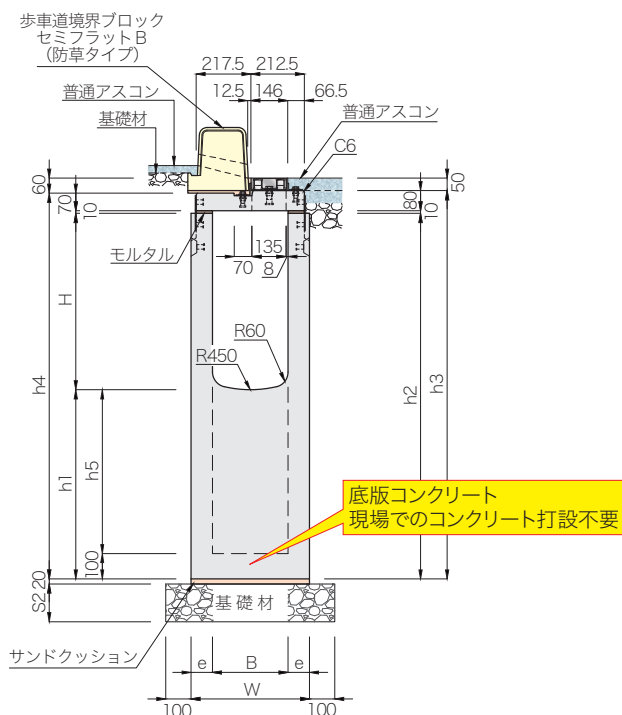

(注) グレーチングはボルト固定式です。また、細目仕様にも変更できます。

400型

布設標準構造図(参考)

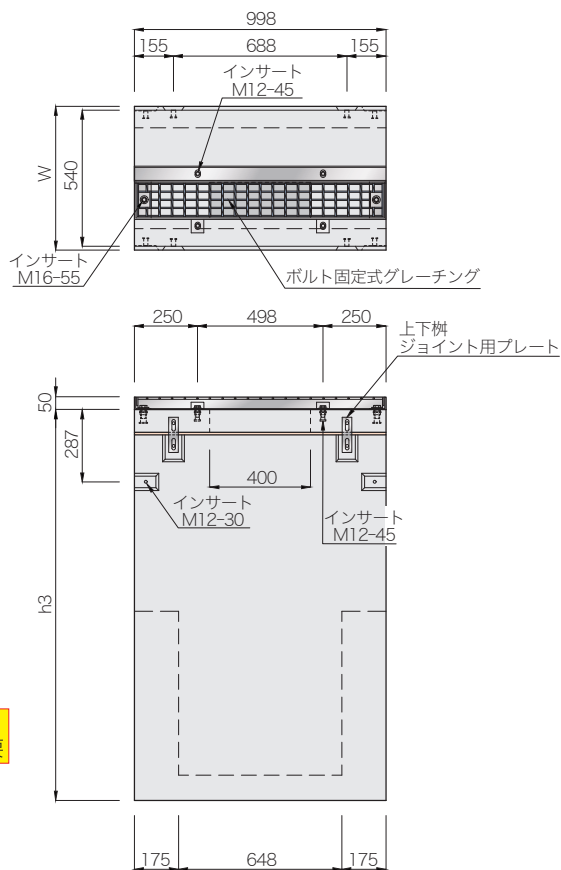
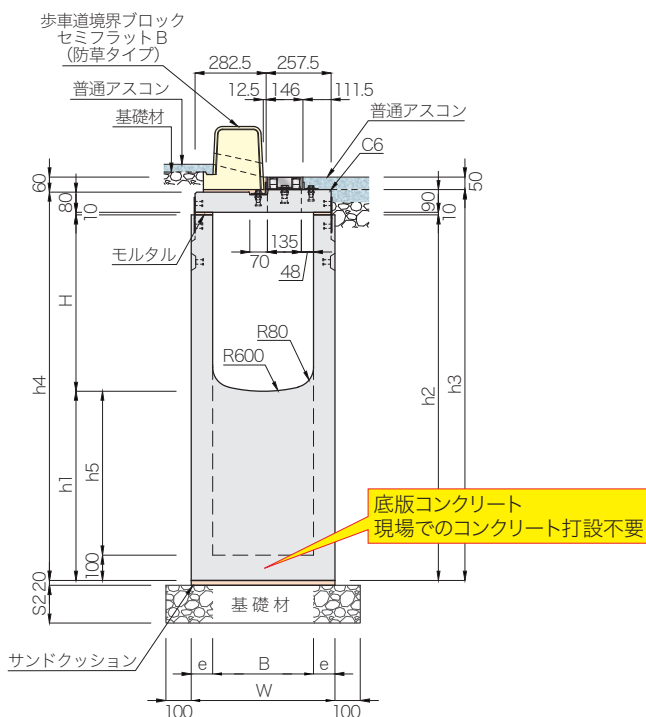

(注) グレーチングはボルト固定式です。また、細目仕様にも変更できます。

都市型側溝 深型集水柵 アングルタイプ H50/70

輸荷重 縦断 **T-25** CAD data DWG SFC

300型 寸法表

呼び名 (B×H-h2)	寸法 (mm)								参考質量(kg)		
	h1	h3	h4	h5	W	e	S2	上部柵	下部柵	合計	
300× 300	650	350	740	730	250	470	85	150	80	394	474
	750	450	840	830	350					458	538
	850	550	940	930	450					522	602
	950	650	1040	1030	550					587	667
	1050	750	1140	1130	650					652	732
	1150	850	1240	1230	750			200		717	797
	1250	950	1340	1330	850					781	861
	1350	1050	1440	1430	950					845	925
	1450	1150	1540	1530	1050					910	990
300× 400	750	350	840	830	250	470	85	150	80	434	514
	850	450	940	930	350					498	578
	950	550	1040	1030	450					563	643
	1050	650	1140	1130	550					627	707
	1150	750	1240	1230	650			200		693	773
	1250	850	1340	1330	750					757	837
	1350	950	1440	1430	850					821	901
	1450	1050	1540	1530	950					886	966
	850	350	940	930	250	470	85	150	80	473	553
300× 500	950	450	1040	1030	350					538	618
	1050	550	1140	1130	450					602	682
	1150	650	1240	1230	550			200		667	747
	1250	750	1340	1330	650					732	812
	1350	850	1440	1430	750					796	876
	1450	950	1540	1530	850					860	940
	950	350	1040	1030	250	470	85	150	80	513	593
	1050	450	1140	1130	350					577	657
	1150	550	1240	1230	450			200		642	722
300× 600	1250	650	1340	1330	550					706	786
	1350	750	1440	1430	650					771	851
	1450	850	1540	1530	750					836	916
	1050	350	1140	1130	250	470	85	150	80	553	633
	1150	450	1240	1230	350			200		618	698
	1250	550	1340	1330	450					682	762
	1350	650	1440	1430	550					746	826
	1450	750	1540	1530	650					812	892
	1050	250	1140	1130	150	470	85	150	80	529	609
300× 800	1150	350	1240	1230	250			200		593	673
	1250	450	1340	1330	350					658	738
	1350	550	1440	1430	450					722	802
	1450	650	1540	1530	550					787	867
	1150	250	1240	1230	150	470	85	200	80	569	649
	1250	350	1340	1330	250					633	713
	1350	450	1440	1430	350					698	778
	1450	550	1540	1530	450					762	842
	1250	250	1340	1330	150	470	85	200	80	609	689
300×1000	1350	350	1440	1430	250					673	753
	1450	450	1540	1530	350					738	818

400型 寸法表

呼び名 (B×H-h2)	寸法 (mm)								参考質量(kg)			
	h1	h3	h4	h5	W	e	S2	上部柵	下部柵	合計		
400× 400	750	350	850	840	250	570	85	150	111	480	591	
	850	450	950	940	350					553	664	
	950	550	1050	1040	450					625	736	
	1050	650	1150	1140	550					698	809	
	1150	750	1250	1240	650			200		771	882	
	1250	850	1350	1340	750					844	955	
	1350	950	1450	1440	850					916	1027	
	1450	1050	1550	1540	950					989	1100	
	400× 500	850	350	950	940	250	570	85	150	111	520	631
950		450	1050	1040	350					593	704	
1050		550	1150	1140	450					665	776	
1150		650	1250	1240	550			200		738	849	
1250		750	1350	1340	650					811	922	
1350		850	1450	1440	750					884	995	
1450		950	1550	1540	850					956	1067	
400× 600		950	350	1050	1040	250	570	85	150	111	560	671
		1050	450	1150	1140	350					633	744
	1150	550	1250	1240	450			200		705	816	
	1250	650	1350	1340	550					778	889	
	1350	750	1450	1440	650					851	962	
	1450	850	1550	1540	750					924	1035	
	400× 700	1050	350	1150	1140	250	570	85	150	111	600	711
		1150	450	1250	1240	350			200		673	784
		1250	550	1350	1340	450					745	856
1350		650	1450	1440	550					818	929	
1450		750	1550	1540	650					891	1002	
400× 800		1150	350	1250	1240	250	570	85	200	111	640	751
		1250	450	1350	1340	350					713	824
		1350	550	1450	1440	450					785	896
		1450	650	1550	1540	550					858	969
	☆ 400× 900	1150	250	1250	1240	150	600	100	200	111	687	798
		1250	350	1350	1340	250					767	878
		1350	450	1450	1440	350					847	958
		1450	550	1550	1540	450					927	1038
		☆ 400×1000	1250	250	1350	1340	150	600	100	200	111	734
1350			350	1450	1440	250					814	925
1450			450	1550	1540	350					894	1005

注(1)グレーチングはボルト固定式です。また、細目仕様にも変更できます。

(2)☆印につきましては型枠を整備中ですので、あらかじめ担当営業にお問い合わせください。