

歩車道境界Rブロック[A・B・C]

CAD data DWG SFC

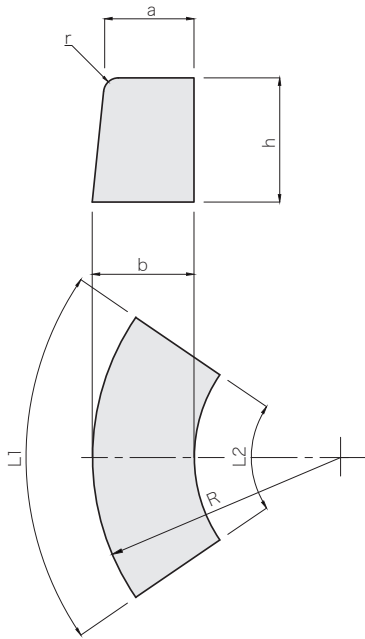

呼び名	寸法 (mm)						1/4 円(90°)		参考質量 (kg)							
	a	b	h	r	R	L1	L2	曲線長さ (mm)		使用本数 (本)						
A形	0.5 mR	150	170	200	20	500	600	398	785	1.3	37					
	1.0 mR					1000						515	1571	2.5	42	
	1.5 mR					1500						600	532	2356	3.9	
	2.0 mR					2000						549	3142	5.2		
	2.5 mR					2500						559	3927	6.5		
	3.0 mR					3000						566	4712	7.9		
	4.0 mR					4000						574	6283	10.5		
	5.0 mR					5000						580	7854	13.0		
B形	0.75 mR	180	205	250	30	750	600	477	1571	2.6	59					
	1.0 mR					1000						527	2356	3.9	63	
	1.5 mR					1500						600	539	3142	5.2	
	2.0 mR					2000						559	4712	7.8		
	3.0 mR					3000						569	6283	10.4		
	4.0 mR					4000						575	7854	13.1		
	5.0 mR					5000						580	9425	15.7		
	6.0 mR					6000						583	9425	15.7		
C形	0.75 mR	180	210	300	30	750	1170	845	1178	1.0	135					
	1.0 mR					1000						600	474	1571	2.6	72
	1.5 mR					1500						610	525	2356	3.9	76
	2.0 mR					2000						600	537	3142	5.2	
	3.0 mR					3000						558	4712	7.8		

(注)○印につきましては、仕入れ品対応です。

歩車道境界Rブロック低7cm[A・B]

CAD data DWG SFC

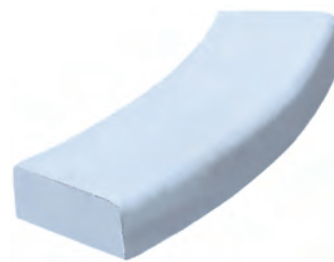
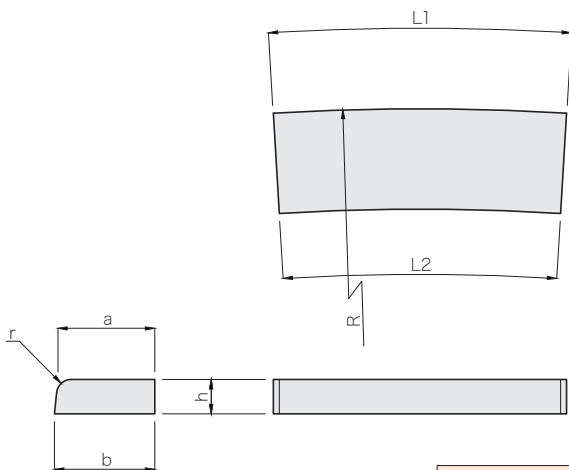

呼び名	寸法 (mm)						1/4 円(90°)		参考質量 (kg)						
	a	b	h	r	R	L1	L2	曲線長さ (mm)		使用本数 (本)					
A形	2.0 mR	163	170	70	20	2000	600	549	3142	5.2	15				
	3.0 mR					3000						566	4712	7.9	16
	4.0 mR					4000						575	6283	10.5	
	5.0 mR					5000						580	7854	13.1	
B形	2.0 mR	198	205	70	30	2000	600	539	3142	5.2	18				
	3.0 mR					3000						559	4712	7.9	19
	4.0 mR					4000						569	6283	10.5	
	5.0 mR					5000						575	7854	13.1	