

I B C排水側溝 乗り入れ一体 I 型 H=50 300型 断面図

単位：mm

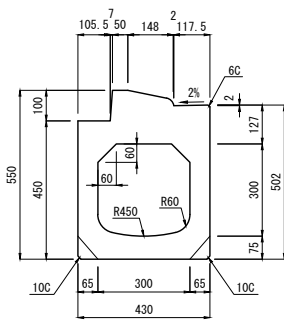

300×300

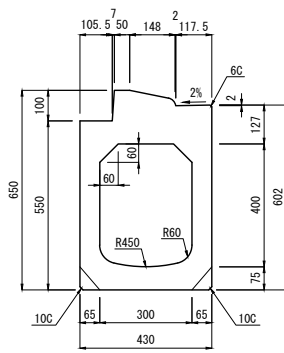

300×400

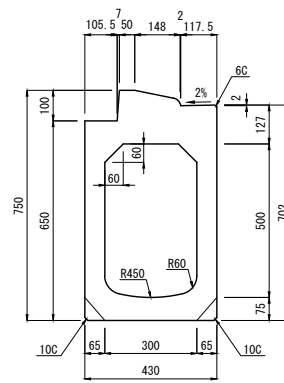

300×500

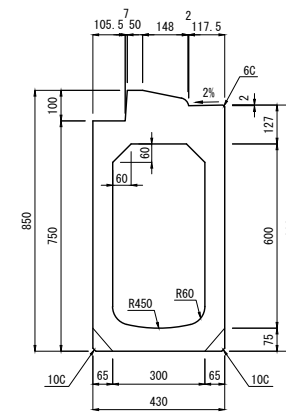

300×600

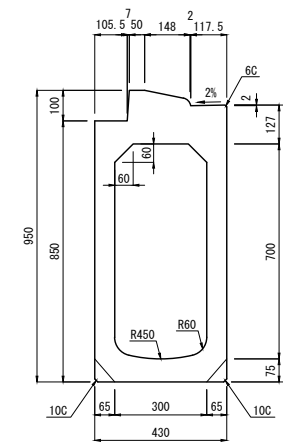

300×700

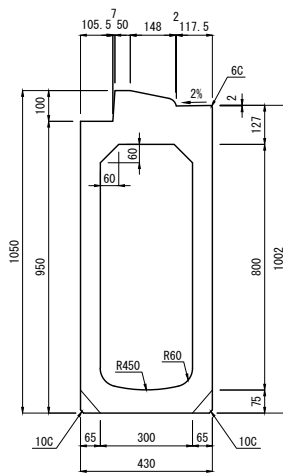

300×800

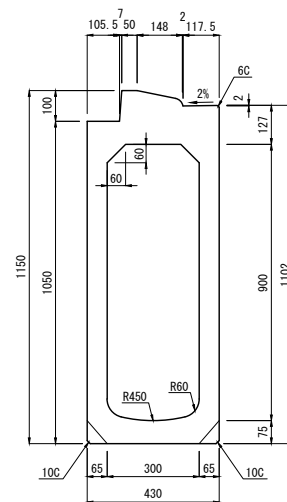

300×900

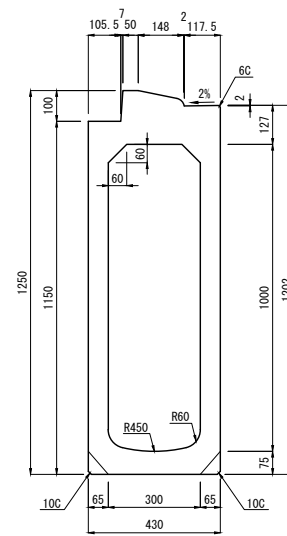

300×1000

製品名	I B C排水側溝 乗り入れ一体 断面図	図面番号	
規格	I 型 H=50 300型	 東洋コンクリート工業株式会社	
製図	E:2010.09.15 R:2022.01.18 縮尺 1:25		

I B C排水側溝 乗り入れ一体 I 型 H=50 400型 断面図

単位：mm

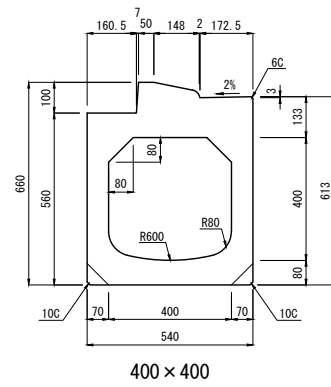

400×400

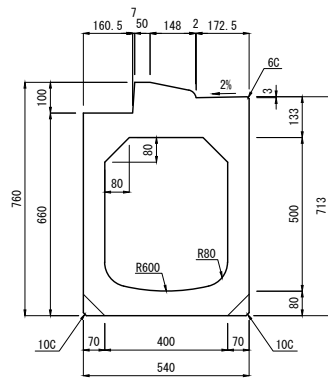

400×500

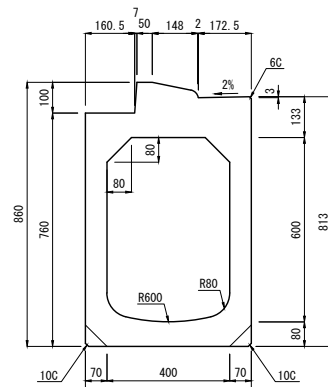

400×600

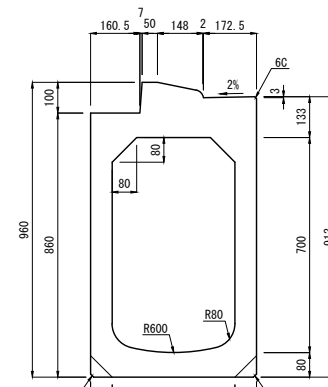

400×700

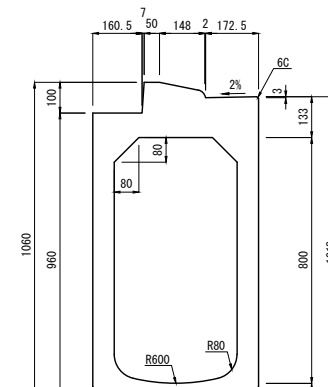

400×800

製品名	I B C排水側溝 乗り入れ一体 断面図			図面番号	
規格	I 型 H=50 400型				東洋コンクリート工業株式会社
製図	E:2010.09.15	R:2022.01.18	縮尺		

I B C排水側溝 乗り入れ一体II型 H=20 300型 断面図

単位：mm

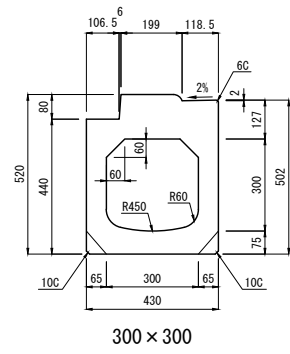

300 × 300

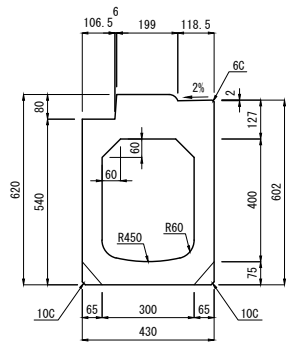

300 × 400

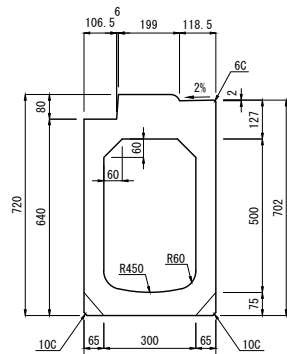

300 × 500

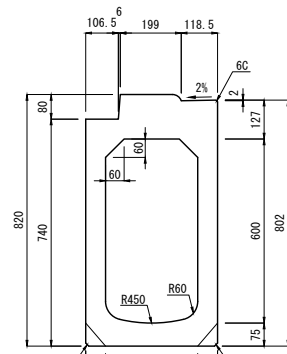

300 × 600

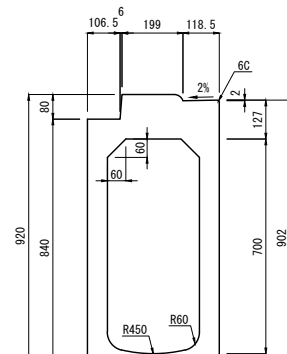

300 × 700

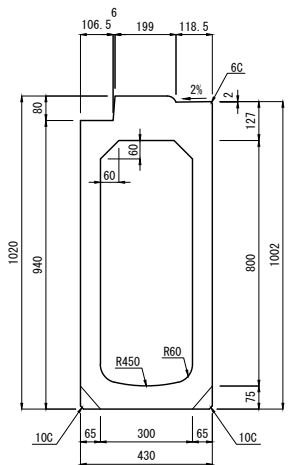

300 × 800

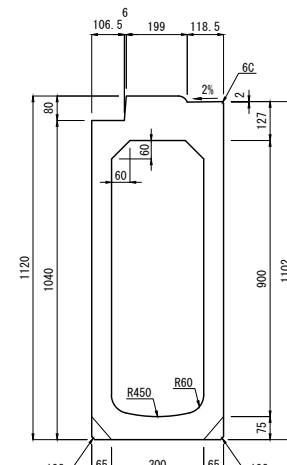

300 × 900

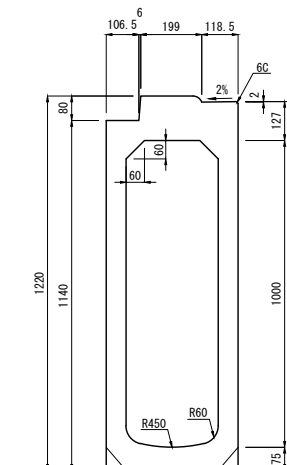



300 × 1000

製品名	I B C排水側溝 乗り入れ一体 断面図	図面番号	
規格	II型 H=20 300型	 東洋コンクリート工業株式会社	
製図	E:2010.09.15 R:2022.01.18 縮尺 1:25		

I B C排水側溝 乗り入れ一体 II型 H=20 400型 断面図

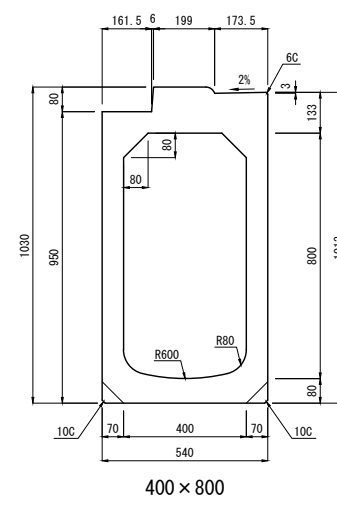
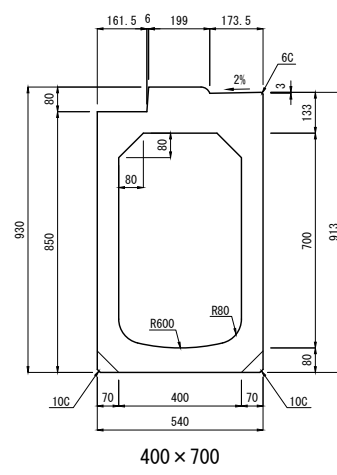
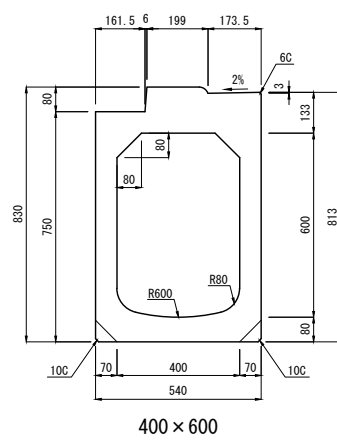
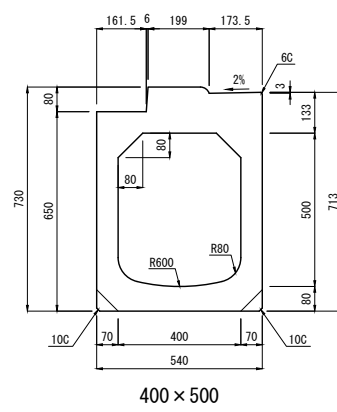
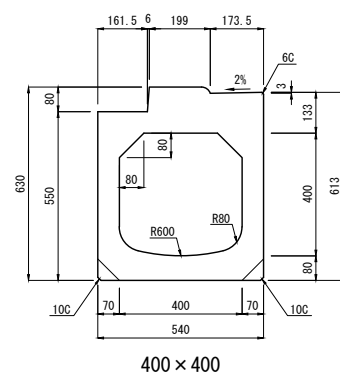
単位：mm



製品名	I B C排水側溝 乗り入れ一体 断面図	図面番号	
規格	II型 H=20 400型	 東洋コンクリート工業株式会社	
製図	E:2010.09.15 R:2022.01.18 縮尺 1:25		

I B C排水側溝 乗り入れ一体II型 H=0-20 300型 断面図

単位：mm

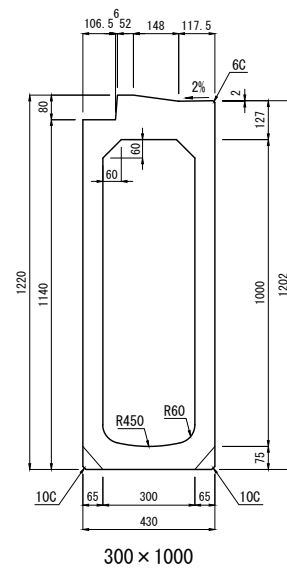
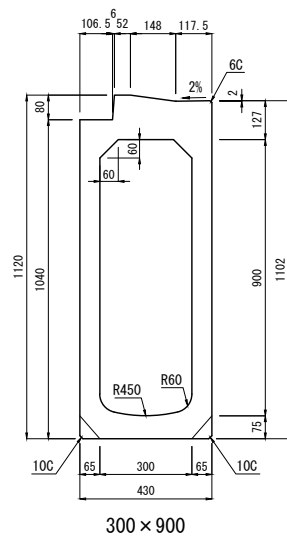
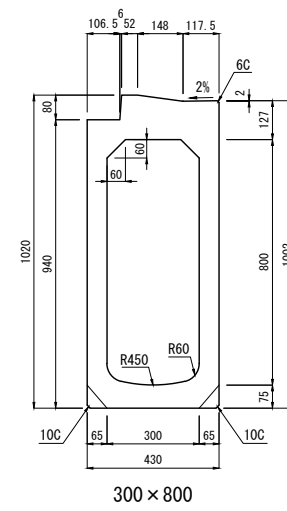
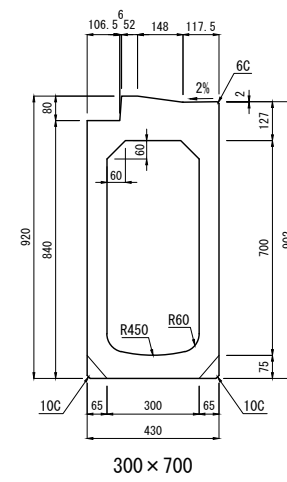
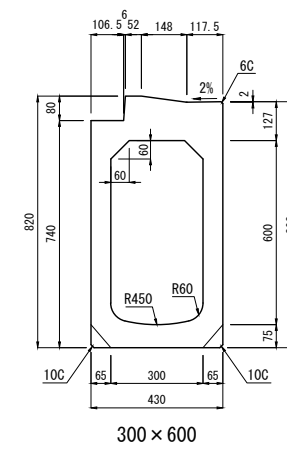
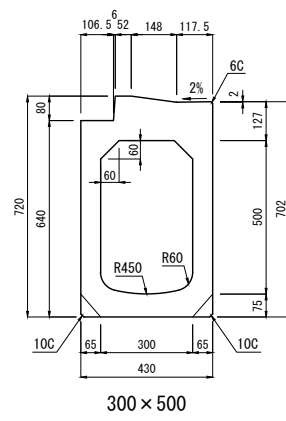
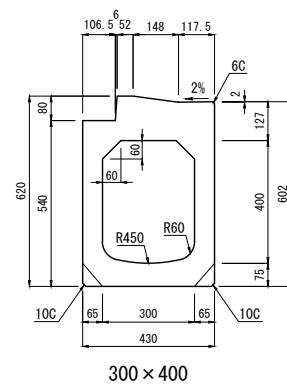
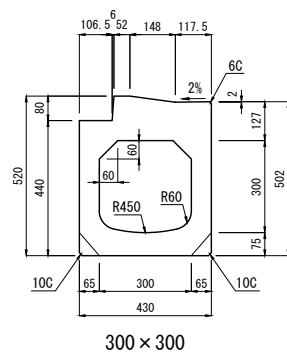

製品名	I B C排水側溝 乗り入れ一体 断面図	図面番号	
規格	II型 H=0-20 300型	 東洋コンクリート工業株式会社	
製図	E:2010.09.15 R:2022.01.18 縮尺 1:25		

I B C排水側溝 乗り入れ一体II型 H=0-20 400型 断面図

単位：mm

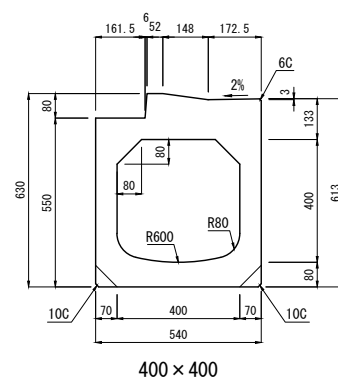

400×400

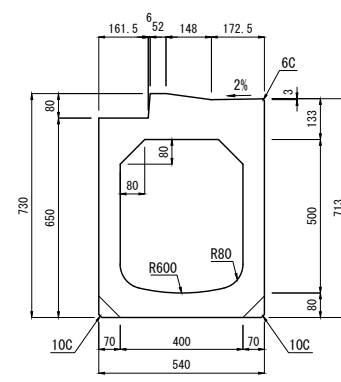

400×500

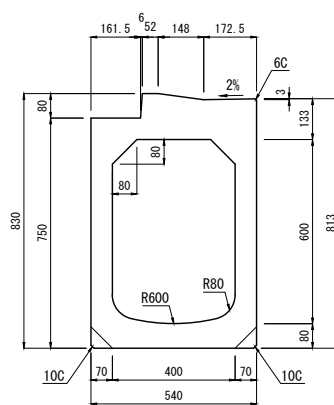

400×600

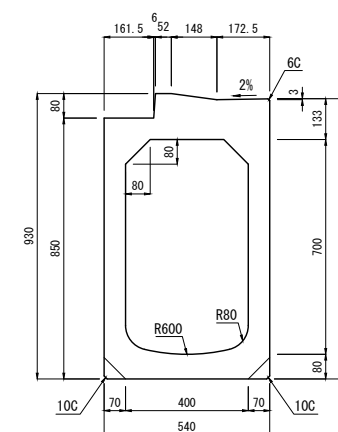

400×700

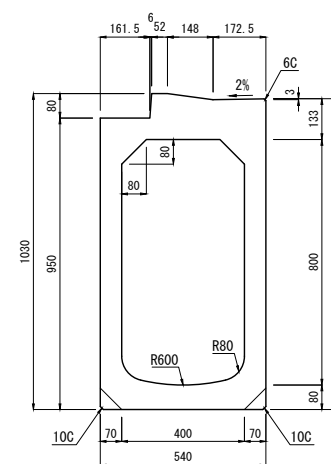

400×800

製品名	I B C排水側溝 乗り入れ一体 断面図			図面番号	
規格	II型 H=0-20 400型				東洋コンクリート工業株式会社
製図	E:2010.09.15	R:2022.01.18	縮尺		