

# 箱型U字側溝 断面図

単位：mm

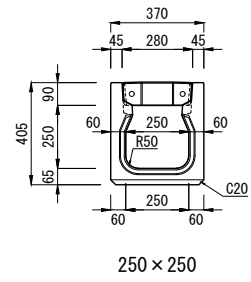

250×250

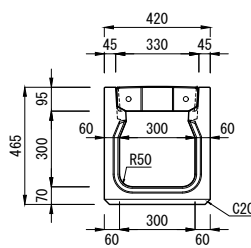

300×300

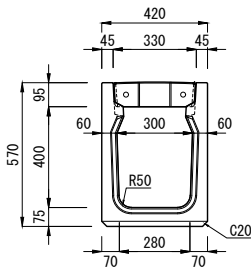

300×400

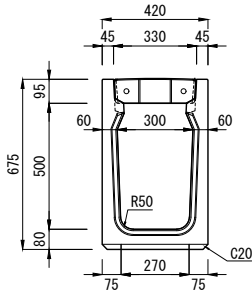

300×500

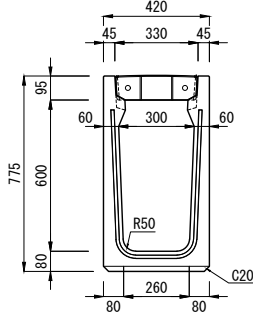

300×600

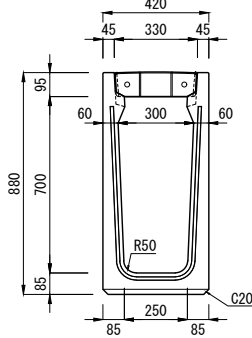

300×700

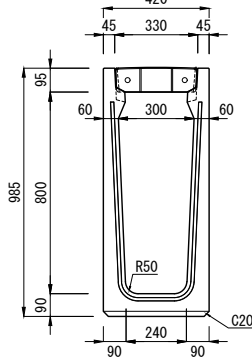

300×800

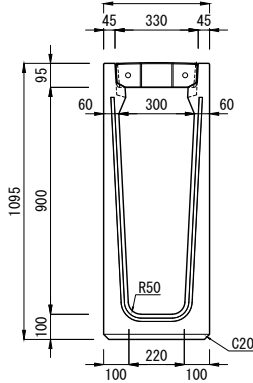

300×900

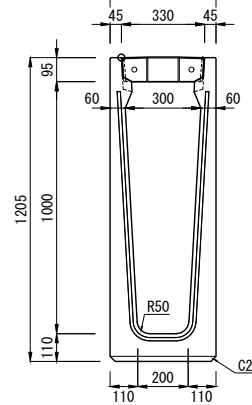

300×1000

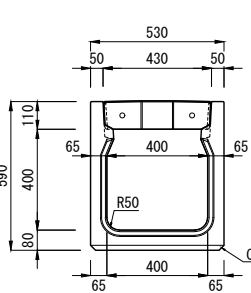
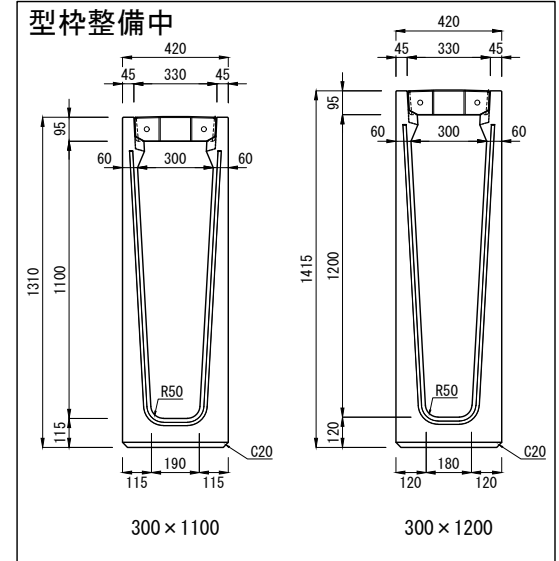

400×400

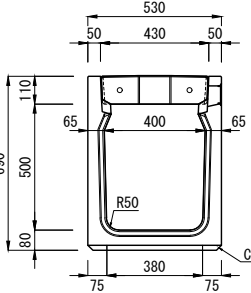

400×500

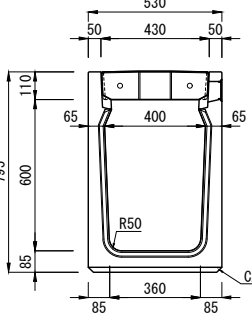

400×600

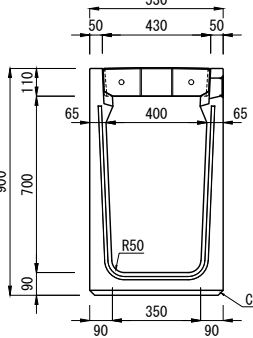

400×700

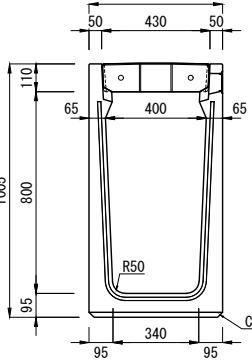

400×800

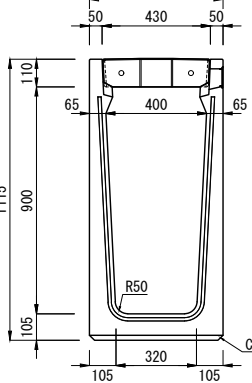

400×900

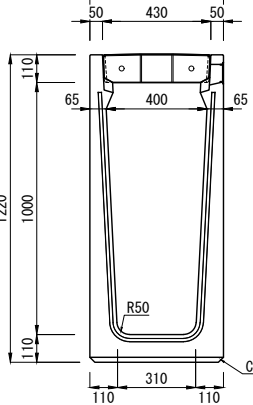

400×1000

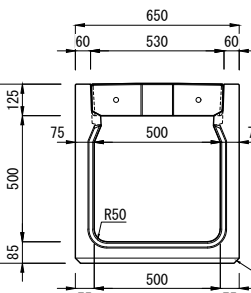
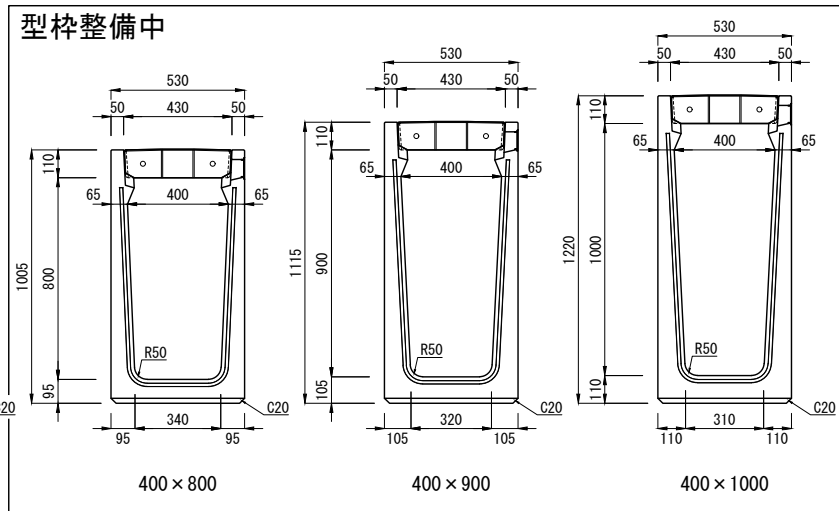

500×500

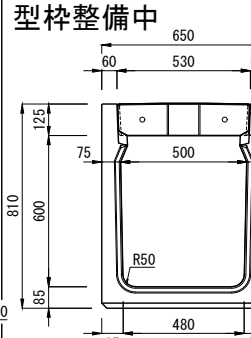

500×600

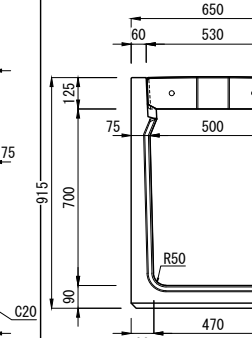

500×700

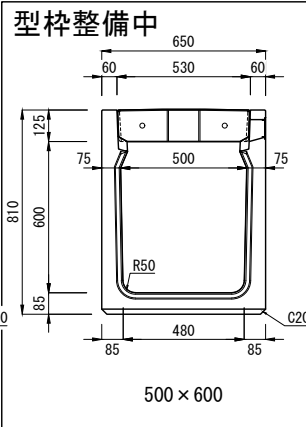

製品名	箱型U字側溝 断面図	製 図	E2015. 10. 28
規 格	250・300・400・500 (T-25縦断)	設 計	R2024. 12. 18
参考質量	縮 尺	1/30	



# 箱型U字側溝 集水柵 断面図

単位：mm

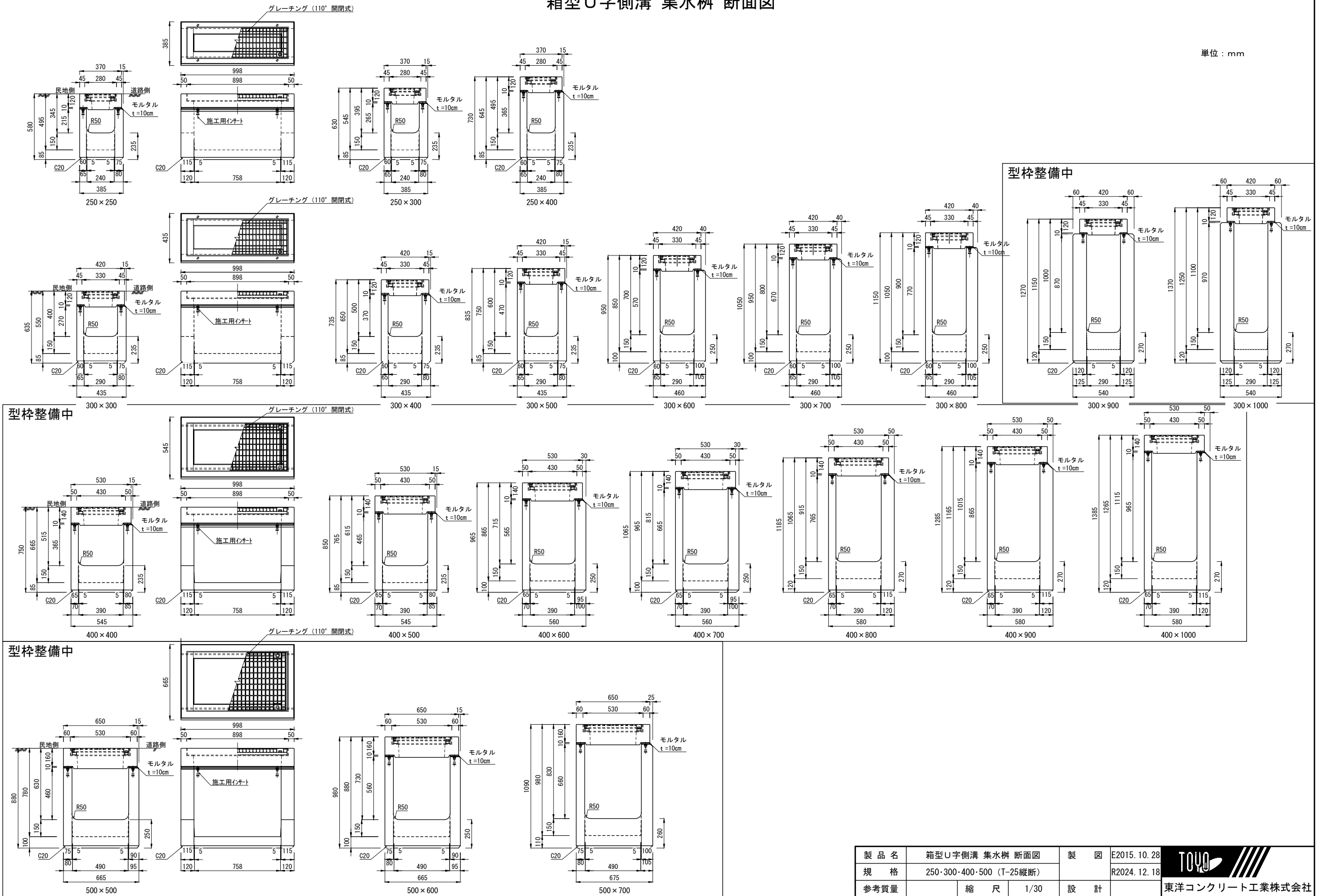

製品名	箱型U字側溝 集水柵 断面図	製 図	E2015. 10. 28
規 格	250・300・400・500 (T-25縦断)	設 計	R2024. 12. 18
参考質量	縮 尺	1/30	東洋コンクリート工業株式会社