

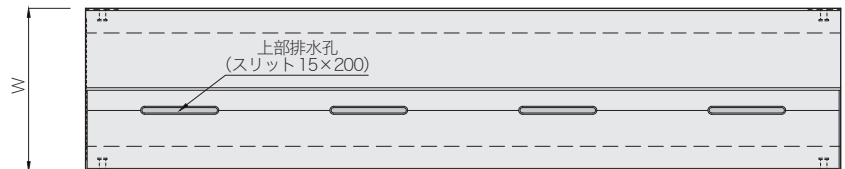

布設標準構造図(参考)

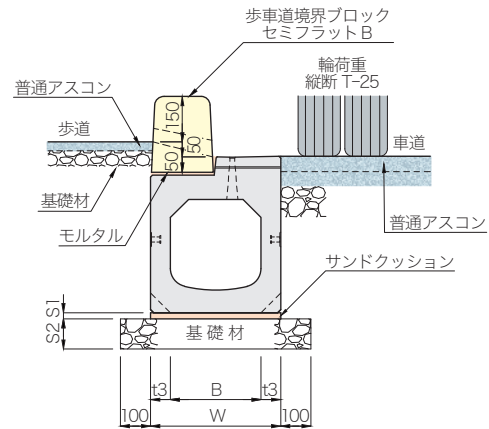

製品エプロン部勾配2%
のため段差を作らない

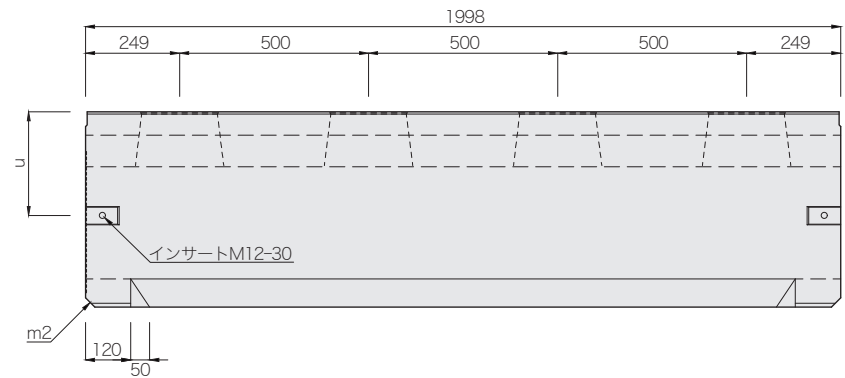
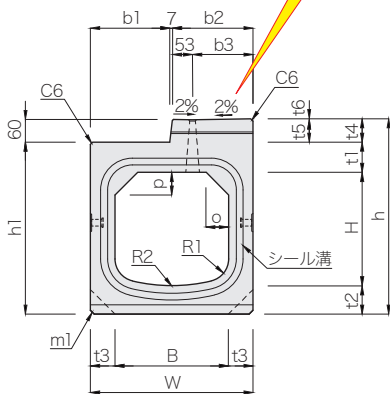

| 呼び名 (B×H) | 寸法 (mm) | | | | | | | | | | | | | | | | | | | | | | | | 参考 質量 (kg) |
|--------------|---------|------|------|------|-----|-----|-----|-----|----|----|----|----|----|----|----|----|----|----|-----|----|-----|----|-----|------|------------------|
| | B | H | h | h1 | W | b1 | b2 | b3 | t1 | t2 | t3 | t4 | t5 | t6 | o | p | m1 | m2 | u | R1 | R2 | S1 | S2 | | |
| 300× 300 | 300 | 300 | 517 | 455 | 430 | 210 | 213 | 160 | 80 | 75 | 65 | 62 | 59 | 3 | 60 | 60 | 10 | 25 | 275 | 60 | 450 | 20 | 100 | 563 | |
| × 400 | | 400 | 617 | 555 | | | | | | | | | | | | | | | | | | | | 624 | |
| × 500 | | 500 | 717 | 655 | | | | | | | | | | | | | | | | | | | | 685 | |
| × 600 | | 600 | 817 | 755 | | | | | | | | | | | | | | | | | | | 150 | 746 | |
| × 700 | | 700 | 917 | 855 | | | | | | | | | | | | | | | | | | | | 807 | |
| × 800 | | 800 | 1017 | 955 | | | | | | | | | | | | | | | | | | | | 868 | |
| × 900 | | 900 | 1117 | 1055 | | | | | | | | | | | | | | | | | | | 200 | 930 | |
| ×1000 | | 1000 | 1217 | 1155 | | | | | | | | | | | | | | | | | | | | 991 | |
| 400× 400 | 400 | 400 | 643 | 580 | 540 | 275 | 258 | 205 | 90 | 90 | 70 | 63 | 59 | 4 | 80 | 80 | 20 | 35 | 340 | 80 | 600 | 20 | 100 | 817 | |
| × 500 | | 500 | 743 | 680 | | | | | | | | | | | | | | | | | | | | 883 | |
| × 600 | | 600 | 843 | 780 | | | | | | | | | | | | | | | | | | | 150 | 949 | |
| × 700 | | 700 | 943 | 880 | | | | | | | | | | | | | | | | | | | | 1015 | |
| × 800 | | 800 | 1043 | 980 | | | | | | | | | | | | | | | | | | | | 1080 | |
| ☆ × 900 | | 900 | 1143 | 1080 | | | | | | | | | | | | | | | | | | | 200 | 1147 | |
| ☆ ×1000 | | 1000 | 1243 | 1180 | | | | | | | | | | | | | | | | | | | | 1212 | |

(注) ☆印につきましては型枠を整備中ですので、あらかじめ担当営業にお問い合わせください。

都市型側溝 グレーチングタイプ

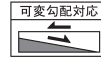

輸荷重
縦断 **T-25**

CAD data
DWG SFC

グレーチング細目対応

布設標準構造図(参考)

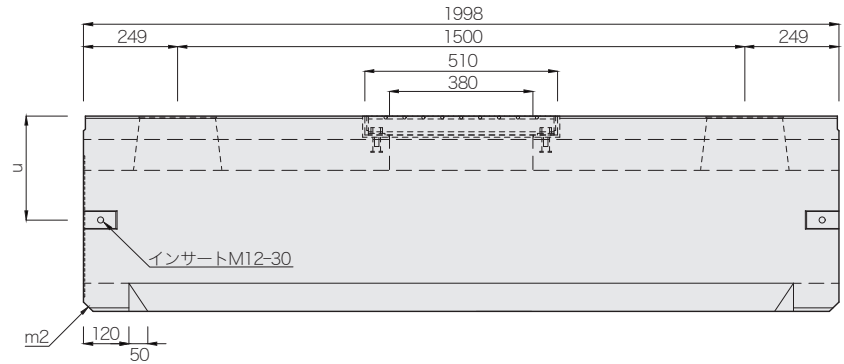
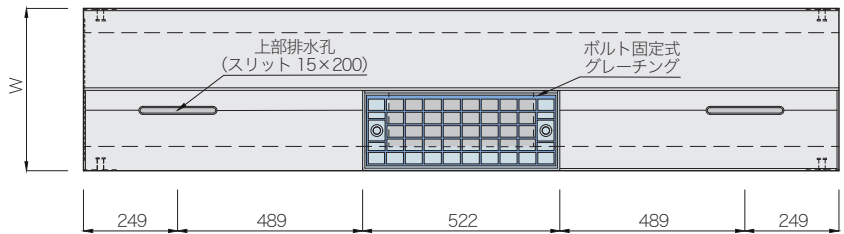
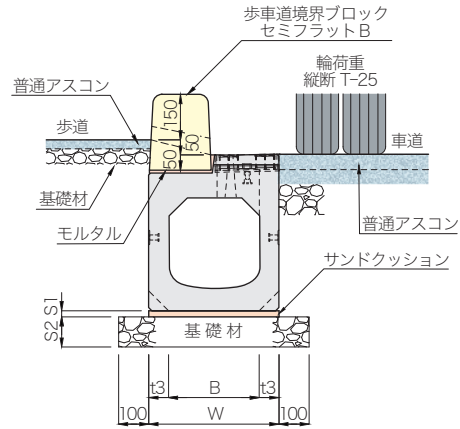

製品エプロン部勾配2%
のため段差を作らない

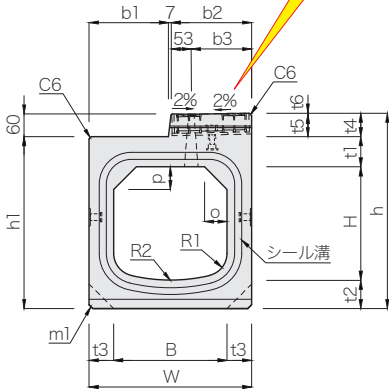

| 呼び名 (B×H) | 寸法 (mm) | | | | | | | | | | | | | | | | | | | | | | | 参考 質量 (kg) |
|--------------|---------|------|------|------|-----|-----|-----|-----|----|----|----|----|----|----|----|----|----|----|-----|----|-----|----|-----|------------------|
| | B | H | h | h1 | W | b1 | b2 | b3 | t1 | t2 | t3 | t4 | t5 | t6 | o | p | m1 | m2 | u | R1 | R2 | S1 | S2 | |
| 300× 300 | 300 | 300 | 517 | 455 | 430 | 210 | 213 | 160 | 80 | 75 | 65 | 62 | 59 | 3 | 60 | 60 | 10 | 25 | 275 | 60 | 450 | 20 | 100 | 542 |
| × 400 | | 400 | 617 | 555 | | | | | | | | | | | | | | | | | | | | 603 |
| × 500 | | 500 | 717 | 655 | | | | | | | | | | | | | | | | | | | | 664 |
| × 600 | | 600 | 817 | 755 | | | | | | | | | | | | | | | | | | | 150 | 725 |
| × 700 | | 700 | 917 | 855 | | | | | | | | | | | | | | | | | | | | 786 |
| × 800 | | 800 | 1017 | 955 | | | | | | | | | | | | | | | | | | | | 847 |
| × 900 | | 900 | 1117 | 1055 | | | | | | | | | | | | | | | | | | | 200 | 908 |
| ×1000 | | 1000 | 1217 | 1155 | | | | | | | | | | | | | | | | | | | | 969 |
| 400× 400 | 400 | 400 | 643 | 580 | 540 | 275 | 258 | 205 | 90 | 90 | 70 | 63 | 59 | 4 | 80 | 80 | 20 | 35 | 340 | 80 | 600 | 20 | 100 | 788 |
| × 500 | | 500 | 743 | 680 | | | | | | | | | | | | | | | | | | | | 854 |
| × 600 | | 600 | 843 | 780 | | | | | | | | | | | | | | | | | | | 150 | 920 |
| × 700 | | 700 | 943 | 880 | | | | | | | | | | | | | | | | | | | | 986 |
| × 800 | | 800 | 1043 | 980 | | | | | | | | | | | | | | | | | | | | 1051 |
| ☆ × 900 | | 900 | 1143 | 1080 | | | | | | | | | | | | | | | | | | | 200 | 1117 |
| ☆ ×1000 | | 1000 | 1243 | 1180 | | | | | | | | | | | | | | | | | | | | 1183 |

注(1) ☆印につきましては型枠を整備中ですので、あらかじめ担当営業にお問い合わせください。

(2) グレーチングはボルト固定式です。また、細目仕様にも変更できます。

都市型側溝 集水柵

輸荷重 縦断 T-25 CAD data DWG SFC

グレーチング細目対応

基本 防草タイプ

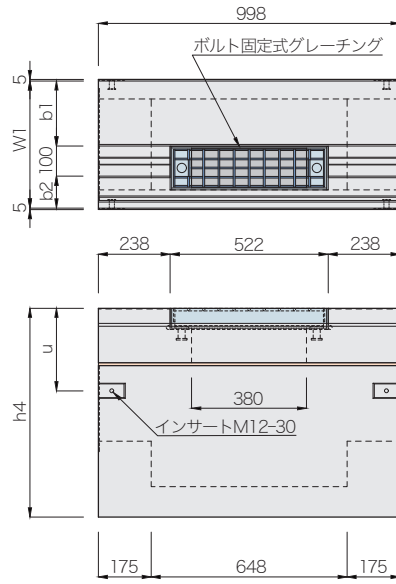
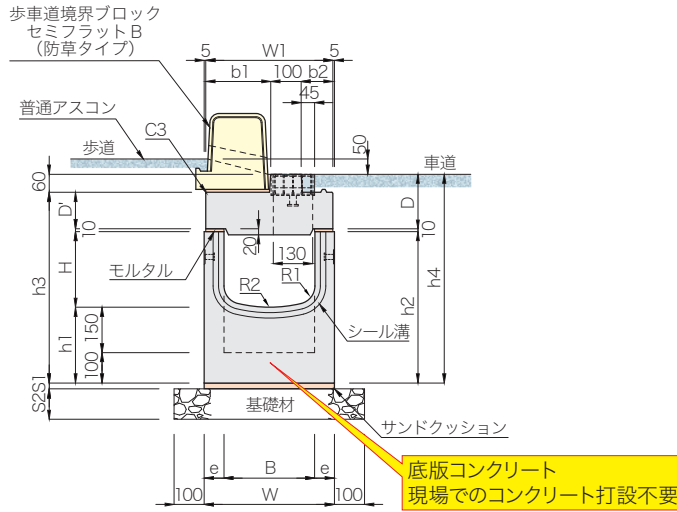

基本タイプ

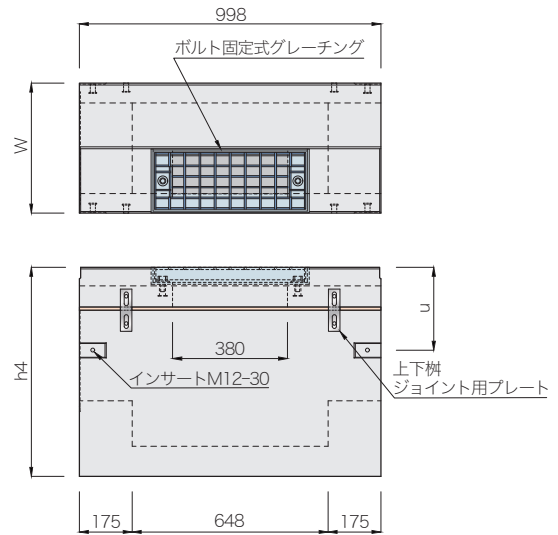
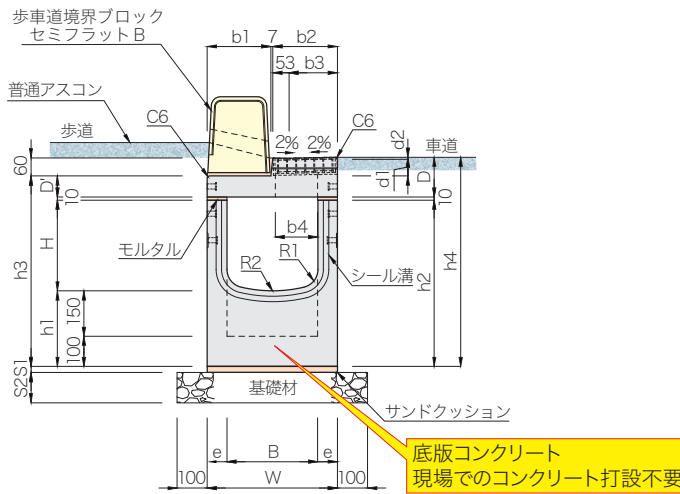

| 呼び名 (B×H) | 寸法 (mm) | | | | | | | | | | | | | | | | | 参考質量 (kg) | | | | | | | | | | | |
|-----------|---------|-----|-----|------|------|------|------|-----|-----|-----|-----|-----|-----|-----|-----|----|----|-----------|-----|-----|-----|-----|-----|-----|-----|-----|-----|-----|-----|
| | B | H | h1 | h2 | h3 | h4 | W | W1 | b1 | b2 | b3 | b4 | D | D' | d1 | d2 | e | u | R1 | R2 | S1 | S2 | 上部柵 | 下部柵 | 合計 | | | | |
| 基本防草タイプ | 300×300 | 300 | 250 | 250 | 500 | 630 | 690 | 430 | 420 | 215 | 105 | - | - | 180 | 120 | - | - | 65 | 273 | 60 | 450 | 20 | 100 | 132 | 262 | 394 | | | |
| | ×400 | | 350 | | 600 | 730 | 790 | | | | | | | | | | | | | | | | | | 293 | 425 | | | |
| | ×500 | | 450 | | 700 | 830 | 890 | | | | | | | | | | | | | | | | | | | 323 | 455 | | |
| | ×600 | | 550 | | 800 | 930 | 990 | | | | | | | | | | | | | | | | 150 | | | 354 | 486 | | |
| | ×700 | | 650 | | 900 | 1030 | 1090 | | | | | | | | | | | | | | | | | | | | 385 | 517 | |
| | ×800 | | 750 | | 1000 | 1130 | 1190 | | | | | | | | | | | | | | | | | | | | | 416 | 548 |
| 基本タイプ | 400×400 | 400 | 340 | 250 | 590 | 740 | 800 | 540 | 530 | 270 | 160 | - | - | 200 | 140 | - | - | 70 | 337 | 80 | 600 | 20 | 100 | 190 | 342 | 532 | | | |
| | ×500 | | 440 | | 690 | 840 | 900 | | | | | | | | | | | | | | | | | | | 375 | 565 | | |
| | ×600 | | 540 | | 790 | 940 | 1000 | | | | | | | | | | | | | | | | 150 | | | 408 | 598 | | |
| | ×700 | | 640 | | 890 | 1040 | 1100 | | | | | | | | | | | | | | | | | | | | 441 | 631 | |
| | ×800 | | 740 | | 990 | 1140 | 1200 | | | | | | | | | | | | | | | | | | | | | 474 | 664 |
| | 300×300 | 300 | 300 | 250 | 550 | 630 | 692 | 430 | - | 210 | 213 | 160 | 140 | 132 | 70 | 59 | 3 | 65 | 275 | 60 | 450 | 20 | 100 | 91 | 277 | 368 | | | |
| | ×400 | | 400 | | 650 | 730 | 792 | | | | | | | | | | | | | | | | | | | | 308 | 399 | |
| | ×500 | | 500 | | 750 | 830 | 892 | | | | | | | | | | | | | | | | | | | | | 338 | 429 |
| ×600 | | 600 | | 850 | 930 | 992 | | | | | | | | | | | | | | | | | 150 | | | 369 | 460 | | |
| ×700 | | 700 | | 950 | 1030 | 1092 | | | | | | | | | | | | | | | | | | | | | 400 | 491 | |
| ×800 | | 800 | | 1050 | 1140 | 1203 | | | 275 | 258 | 205 | 179 | 143 | 80 | 59 | 4 | 70 | 340 | 80 | 600 | 20 | 100 | 123 | 362 | 485 | | | | |
| | | | | | | | | | | | | | | | | | | | | | | | | | | | 395 | 518 | |
| | | | | | | | | | | | | | | | | | | | | | | | 150 | | | | 428 | 551 | |
| | | | | | | | | | | | | | | | | | | | | | | | | | | | 461 | 584 | |
| | | | | | | | | | | | | | | | | | | | | | | | | | | | 494 | 617 | |

(注) グレーチングはボルト固定式です。また、細目仕様にも変更できます。

300型

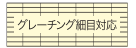

基本タイプ

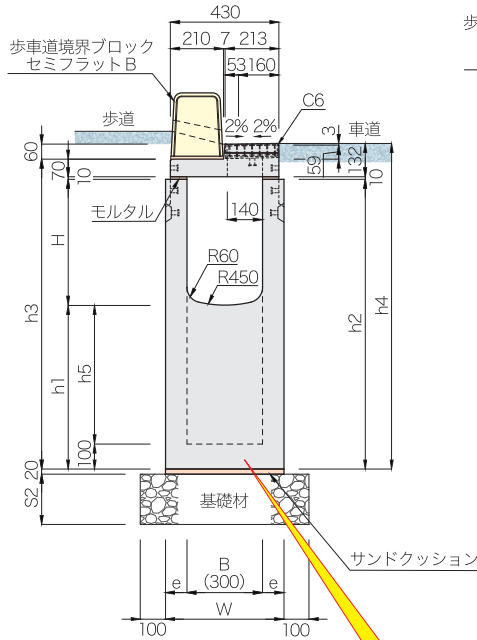

基本 防草タイプ

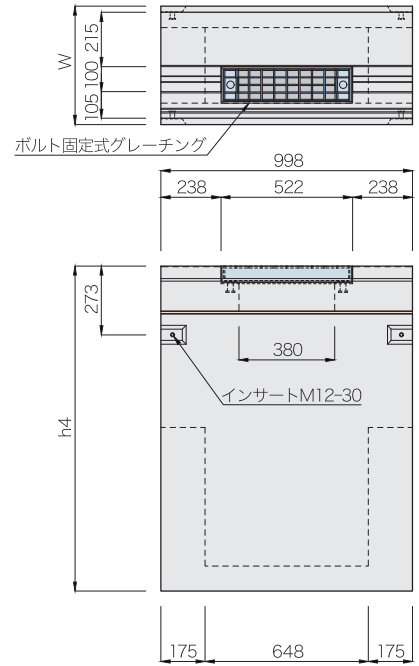
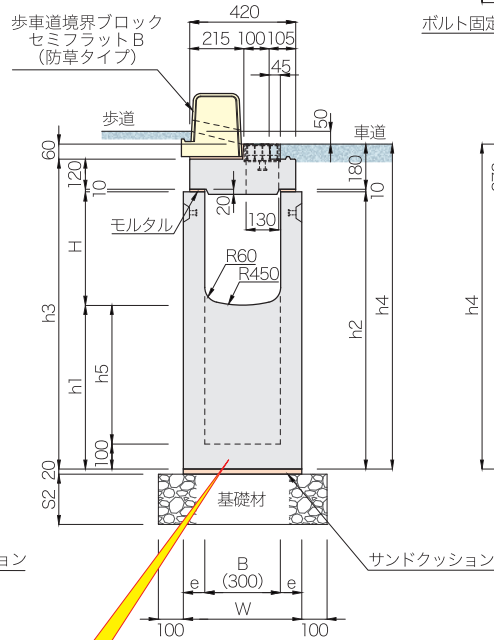

(注) グレーチングはボルト固定式です。また、細目仕様にも変更できます。

400型

基本タイプ

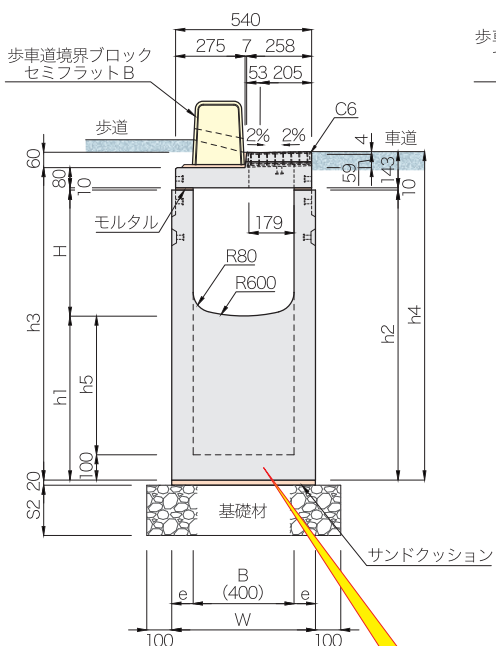

基本 防草タイプ

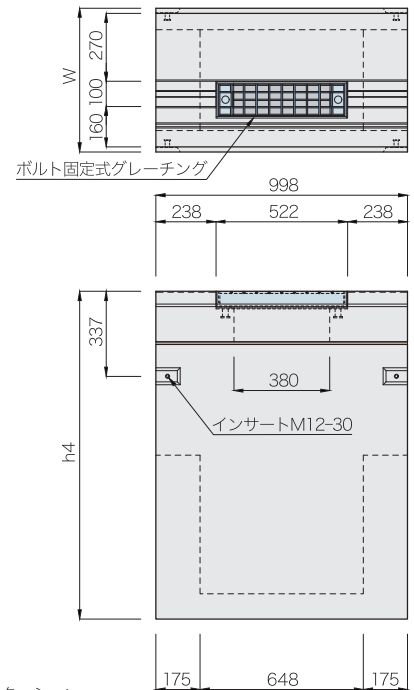
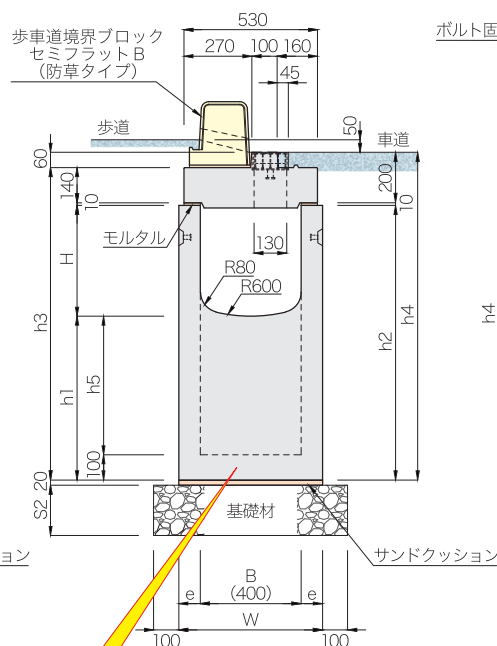

(注) グレーチングはボルト固定式です。また、細目仕様にも変更できます。

基本タイプ

| 呼び名 (B×H-h2) | 寸法 (mm) | | | | | | | | 参考質量 (kg) | | | | |
|-----------------|----------|-----------|------|------|------|------|-----|-----|-----------|-----|------|------|-----|
| | h1 | h3 | h4 | h5 | W | e | S2 | 上部枳 | 下部枳 | 合計 | | | |
| 300× 300 | 650 | 350 | 730 | 792 | 250 | 470 | 85 | 150 | 91 | 394 | 485 | | |
| | 750 | 450 | 830 | 892 | 350 | | | | | 458 | 549 | | |
| | 850 | 550 | 930 | 992 | 450 | | | | | 522 | 613 | | |
| | 950 | 650 | 1030 | 1092 | 550 | | | | | 587 | 678 | | |
| | 1050 | 750 | 1130 | 1192 | 650 | | | | | 652 | 743 | | |
| | 1150 | 850 | 1230 | 1292 | 750 | | | 200 | | 717 | 808 | | |
| | 1250 | 950 | 1330 | 1392 | 850 | | | | | 781 | 872 | | |
| | 1350 | 1050 | 1430 | 1492 | 950 | | | | | 845 | 936 | | |
| | 1450 | 1150 | 1530 | 1592 | 1050 | | | | | 910 | 1001 | | |
| | 300× 400 | 750 | 350 | 830 | 892 | 250 | 470 | 85 | 150 | 91 | 434 | 525 | |
| 850 | | 450 | 930 | 992 | 350 | | | | | 498 | 589 | | |
| 950 | | 550 | 1030 | 1092 | 450 | | | | | 563 | 654 | | |
| 1050 | | 650 | 1130 | 1192 | 550 | | | | | 627 | 718 | | |
| 1150 | | 750 | 1230 | 1292 | 650 | | | 200 | | 693 | 784 | | |
| 1250 | | 850 | 1330 | 1392 | 750 | | | | | 757 | 848 | | |
| 1350 | | 950 | 1430 | 1492 | 850 | | | | | 821 | 912 | | |
| 1450 | | 1050 | 1530 | 1592 | 950 | | | | | 886 | 977 | | |
| 300× 500 | | 850 | 350 | 930 | 992 | 250 | 470 | 85 | 150 | 91 | 473 | 564 | |
| | | 950 | 450 | 1030 | 1092 | 350 | | | | | 538 | 629 | |
| | 1050 | 550 | 1130 | 1192 | 450 | | | | | 602 | 693 | | |
| | 1150 | 650 | 1230 | 1292 | 550 | | | 200 | | 667 | 758 | | |
| | 1250 | 750 | 1330 | 1392 | 650 | | | | | 732 | 823 | | |
| | 1350 | 850 | 1430 | 1492 | 750 | | | | | 796 | 887 | | |
| | 1450 | 950 | 1530 | 1592 | 850 | | | | | 860 | 951 | | |
| | 300× 600 | 950 | 350 | 1030 | 1092 | 250 | 470 | 85 | 150 | 91 | 513 | 604 | |
| | | 1050 | 450 | 1130 | 1192 | 350 | | | | | 577 | 668 | |
| | | 1150 | 550 | 1230 | 1292 | 450 | | | 200 | | 642 | 733 | |
| 1250 | | 650 | 1330 | 1392 | 550 | | | | | 706 | 797 | | |
| 1350 | | 750 | 1430 | 1492 | 650 | | | | | 771 | 862 | | |
| 1450 | | 850 | 1530 | 1592 | 750 | | | | | 836 | 927 | | |
| 300× 700 | | 1050 | 350 | 1130 | 1192 | 250 | 470 | 85 | 150 | 91 | 553 | 644 | |
| | | 1150 | 450 | 1230 | 1292 | 350 | | | 200 | | 618 | 709 | |
| | | 1250 | 550 | 1330 | 1392 | 450 | | | | | 682 | 773 | |
| | | 1350 | 650 | 1430 | 1492 | 550 | | | | | 746 | 837 | |
| | 1450 | 750 | 1530 | 1592 | 650 | | | | | 812 | 903 | | |
| | 300× 800 | 1050 | 250 | 1130 | 1192 | 150 | 470 | 85 | 150 | 91 | 529 | 620 | |
| | | 1150 | 350 | 1230 | 1292 | 250 | | | 200 | | 593 | 684 | |
| | | 1250 | 450 | 1330 | 1392 | 350 | | | | | 658 | 749 | |
| | | 1350 | 550 | 1430 | 1492 | 450 | | | | | 722 | 813 | |
| | | 1450 | 650 | 1530 | 1592 | 550 | | | | | 787 | 878 | |
| 300× 900 | | 1150 | 250 | 1230 | 1292 | 150 | 470 | 85 | 200 | 91 | 569 | 660 | |
| | | 1250 | 350 | 1330 | 1392 | 250 | | | | | 633 | 724 | |
| | | 1350 | 450 | 1430 | 1492 | 350 | | | | | 698 | 789 | |
| | | 1450 | 550 | 1530 | 1592 | 450 | | | | | 762 | 853 | |
| | | 300×1000 | 1250 | 250 | 1330 | 1392 | 150 | 470 | 85 | 200 | 91 | 609 | 700 |
| | 1350 | | 350 | 1430 | 1492 | 250 | | | | | 673 | 764 | |
| | 1450 | | 450 | 1530 | 1592 | 350 | | | | | 738 | 829 | |
| | 400× 400 | | 750 | 350 | 840 | 903 | 250 | 570 | 85 | 150 | 123 | 480 | 603 |
| | | | 850 | 450 | 940 | 1003 | 350 | | | | | 553 | 676 |
| | | | 950 | 550 | 1040 | 1103 | 450 | | | | | 625 | 748 |
| 1050 | | | 650 | 1140 | 1203 | 550 | | | | | 698 | 821 | |
| 1150 | | | 750 | 1240 | 1303 | 650 | | | 200 | | 771 | 894 | |
| 1250 | | | 850 | 1340 | 1403 | 750 | | | | | 844 | 967 | |
| 1350 | | | 950 | 1440 | 1503 | 850 | | | | | 916 | 1039 | |
| 1450 | | 1050 | 1540 | 1603 | 950 | | | | | 989 | 1112 | | |
| 400× 500 | | 850 | 350 | 940 | 1003 | 250 | 570 | 85 | 150 | 123 | 520 | 643 | |
| | | 950 | 450 | 1040 | 1103 | 350 | | | | | 593 | 716 | |
| | 1050 | 550 | 1140 | 1203 | 450 | | | | | 665 | 788 | | |
| | 1150 | 650 | 1240 | 1303 | 550 | | | 200 | | 738 | 861 | | |
| | 1250 | 750 | 1340 | 1403 | 650 | | | | | 811 | 934 | | |
| | 1350 | 850 | 1440 | 1503 | 750 | | | | | 884 | 1007 | | |
| | 1450 | 950 | 1540 | 1603 | 850 | | | | | 956 | 1079 | | |
| | 400× 600 | 950 | 350 | 1040 | 1103 | 250 | 570 | 85 | 150 | 123 | 560 | 683 | |
| | | 1050 | 450 | 1140 | 1203 | 350 | | | 200 | | 633 | 756 | |
| | | 1150 | 550 | 1240 | 1303 | 450 | | | | | 705 | 828 | |
| 1250 | | 650 | 1340 | 1403 | 550 | | | | | 778 | 901 | | |
| 1350 | | 750 | 1440 | 1503 | 650 | | | | | 851 | 974 | | |
| 1450 | | 850 | 1540 | 1603 | 750 | | | | | 924 | 1047 | | |
| 400× 700 | | 1050 | 350 | 1140 | 1203 | 250 | 570 | 85 | 150 | 123 | 600 | 723 | |
| | | 1150 | 450 | 1240 | 1303 | 350 | | | 200 | | 673 | 796 | |
| | | 1250 | 550 | 1340 | 1403 | 450 | | | | | 745 | 868 | |
| | | 1350 | 650 | 1440 | 1503 | 550 | | | | | 818 | 941 | |
| | 1450 | 750 | 1540 | 1603 | 650 | | | | | 891 | 1014 | | |
| | 400× 800 | 1150 | 350 | 1240 | 1303 | 250 | 570 | 85 | 200 | 123 | 640 | 763 | |
| | | 1250 | 450 | 1340 | 1403 | 350 | | | | | 713 | 836 | |
| | | 1350 | 550 | 1440 | 1503 | 450 | | | | | 785 | 908 | |
| | | 1450 | 650 | 1540 | 1603 | 550 | | | | | 858 | 981 | |
| | | ☆400× 900 | 1150 | 250 | 1240 | 1303 | 150 | 600 | 100 | 200 | 123 | 687 | 810 |
| 1250 | | | 350 | 1340 | 1403 | 250 | | | | | 767 | 890 | |
| 1350 | | | 450 | 1440 | 1503 | 350 | | | | | 847 | 970 | |
| 1450 | | | 550 | 1540 | 1603 | 450 | | | | | 927 | 1050 | |
| ☆400×1000 | | | 1250 | 250 | 1340 | 1403 | 150 | 600 | 100 | 200 | 123 | 734 | 857 |
| | | | 1350 | 350 | 1440 | 1503 | 250 | | | | | 814 | 937 |
| | 1450 | | 450 | 1540 | 1603 | 350 | | | | | 894 | 1017 | |

基本 防草タイプ

| 呼び名 (B×H-h2) | 寸法 (mm) | | | | | | | | 参考質量 (kg) | | | | |
|-------------------|-------------------|-------------------|------|------|------|------|-----|-----|-----------|-----|------|------|-----|
| | h1 | h3 | h4 | h5 | W | e | S2 | 上部枳 | 下部枳 | 合計 | | | |
| 300× 300 (250) | 600 | 350 | 730 | 790 | 250 | 470 | 85 | 150 | 132 | 374 | 506 | | |
| | 700 | 450 | 830 | 890 | 350 | | | | | 438 | 570 | | |
| | 800 | 550 | 930 | 990 | 450 | | | | | 502 | 634 | | |
| | 900 | 650 | 1030 | 1090 | 550 | | | | | 567 | 699 | | |
| | 1000 | 750 | 1130 | 1190 | 650 | | | | | 632 | 764 | | |
| | 1100 | 850 | 1230 | 1290 | 750 | | | 200 | | 697 | 829 | | |
| | 1200 | 950 | 1330 | 1390 | 850 | | | | | 761 | 893 | | |
| | 1300 | 1050 | 1430 | 1490 | 950 | | | | | 825 | 957 | | |
| | 1400 | 1150 | 1530 | 1590 | 1050 | | | | | 890 | 1022 | | |
| | 300× 400 (350) | 700 | 350 | 830 | 890 | 250 | 470 | 85 | 150 | 132 | 414 | 546 | |
| 800 | | 450 | 930 | 990 | 350 | | | | | 478 | 610 | | |
| 900 | | 550 | 1030 | 1090 | 450 | | | | | 543 | 675 | | |
| 1000 | | 650 | 1130 | 1190 | 550 | | | | | 607 | 739 | | |
| 1100 | | 750 | 1230 | 1290 | 650 | | | 200 | | 673 | 805 | | |
| 1200 | | 850 | 1330 | 1390 | 750 | | | | | 737 | 869 | | |
| 1300 | | 950 | 1430 | 1490 | 850 | | | | | 801 | 933 | | |
| 1400 | | 1050 | 1530 | 1590 | 950 | | | | | 866 | 998 | | |
| 300× 500 (450) | | 800 | 350 | 930 | 990 | 250 | 470 | 85 | 150 | 132 | 453 | 585 | |
| | | 900 | 450 | 1030 | 1090 | 350 | | | | | 518 | 650 | |
| | 1000 | 550 | 1130 | 1190 | 450 | | | | | 582 | 714 | | |
| | 1100 | 650 | 1230 | 1290 | 550 | | | 200 | | 647 | 779 | | |
| | 1200 | 750 | 1330 | 1390 | 650 | | | | | 712 | 844 | | |
| | 1300 | 850 | 1430 | 1490 | 750 | | | | | 776 | 908 | | |
| | 1400 | 950 | 1530 | 1590 | 850 | | | | | 840 | 972 | | |
| | 300× 600 (550) | 900 | 350 | 1030 | 1090 | 250 | 470 | 85 | 150 | 132 | 493 | 625 | |
| | | 1000 | 450 | 1130 | 1190 | 350 | | | | | 557 | 689 | |
| | | 1100 | 550 | 1230 | 1290 | 450 | | | 200 | | 622 | 754 | |
| 1200 | | 650 | 1330 | 1390 | 550 | | | | | 686 | 818 | | |
| 1300 | | 750 | 1430 | 1490 | 650 | | | | | 751 | 883 | | |
| 1400 | | 850 | 1530 | 1590 | 750 | | | | | 816 | 948 | | |
| 300× 700 (650) | | 1000 | 350 | 1130 | 1190 | 250 | 470 | 85 | 150 | 132 | 533 | 665 | |
| | | 1100 | 450 | 1230 | 1290 | 350 | | | 200 | | 598 | 730 | |
| | | 1200 | 550 | 1330 | 1390 | 450 | | | | | 662 | 794 | |
| | | 1300 | 650 | 1430 | 1490 | 550 | | | | | 726 | 858 | |
| | 1400 | 750 | 1530 | 1590 | 650 | | | | | 792 | 924 | | |
| | 300× 800 (750) | 1000 | 250 | 1130 | 1190 | 150 | 470 | 85 | 150 | 132 | 509 | 641 | |
| | | 1100 | 350 | 1230 | 1290 | 250 | | | 200 | | 573 | 705 | |
| | | 1200 | 450 | 1330 | 1390 | 350 | | | | | 638 | 770 | |
| | | 1300 | 550 | 1430 | 1490 | 450 | | | | | 702 | 834 | |
| | | 1400 | 650 | 1530 | 1590 | 550 | | | | | 767 | 899 | |
| 300× 900 (850) | | 1100 | 250 | 1230 | 1290 | 150 | 470 | 85 | 200 | 132 | 549 | 681 | |
| | | 1200 | 350 | 1330 | 1390 | 250 | | | | | 613 | 745 | |
| | | 1300 | 450 | 1430 | 1490 | 350 | | | | | 678 | 810 | |
| | | 1400 | 550 | 1530 | 1590 | 450 | | | | | 742 | 874 | |
| | | 300×1000 (950) | 1200 | 250 | 1330 | 1390 | 150 | 470 | 85 | 200 | 132 | 589 | 721 |
| | 1300 | | 350 | 1430 | 1490 | 250 | | | | | 653 | 785 | |
| | 1400 | | 450 | 1530 | 1590 | 350 | | | | | 718 | 850 | |
| | 400× 400 (340) | | 690 | 350 | 840 | 900 | 250 | 570 | 85 | 150 | 190 | 456 | 646 |
| | | | 790 | 450 | 940 | 1000 | 350 | | | | | 529 | 719 |
| | | | 890 | 550 | 1040 | 1100 | 450 | | | | | 601 | 791 |
| 990 | | | 650 | 1140 | 1200 | 550 | | | | | 674 | 864 | |
| 1090 | | | 750 | 1240 | 1300 | 650 | | | 200 | | 747 | 937 | |
| 1190 | | | 850 | 1340 | 1400 | 750 | | | | | 820 | 1010 | |